

Request for Quotation (RFQ)

Date: **30 April 2024**

RFQ number: **20240401**

Quotes due no later than: **Monday, 20 May 2024 at 4:00 PM CT.** All questions pertaining to this RFQ are due by **4:00 PM CT on Friday, 10 May 2024.**

Provide quotes to: Stan Peters, Contracting Officer at stan_peters@ca11.uscourts.gov

The United States Court of Appeals for the Eleventh Circuit is requesting quotes for the services described below:

STATEMENT OF WORK (SOW)

1.1 INTRODUCTION:

A private restroom inside an office suite on the ninth floor of the Hugo L. Black United States Courthouse located in Birmingham, Alabama is worn from years of use and needs renovation.

1.2 OBJECTIVES:

Contractor shall repair, refinish, replace, and install items in the restroom as described below.

1.3 SCOPE:

The scope of work to be completed by the contractor includes cabinetry, drywall work, wallcovering, flooring, painting, and minor electrical and plumbing work. The adjoining office space will be occupied during the renovation.

1.4 SPECIAL REQUIREMENTS/INFORMATION:

Contractor shall provide the following information with quotation:

1. Evidence of a minimum of five (5) years' experience. Subcontractors shall each have a minimum of two (2) years' experience in the construction subtrade of the work being performed.
2. Proof of an active contractor's license in Alabama, Florida, or Georgia. The Contractor shall, without additional expense to the Judiciary, be responsible for obtaining any necessary licenses and permits, and for complying with any Federal, State, and municipal laws, codes, and regulations applicable to the performance of the work. This requirement also applies to subcontractors, such as electrical, that require active contractor's license for their applicable subtrade.
3. At least three (3) references from similar construction projects that you have completed. The projects shall be like this project in terms of scope, cost and completed in a commercial setting. Include client name, contact name, phone number, and email address. Describe the type of work completed, the project cost, the project duration, and whether the project was completed on time. If the project was not completed on time, provide an explanation for delays.

4. Evidence of a Contractor's Experience Modification Rating (EMR) of 1 or less.
5. A current business credit report from Dun and Bradstreet, Experian, or Equifax. If contractor is a sole proprietorship, partnership, or limited liability company (LLC), a current personal credit report from Transunion, Experian, or Equifax for each principal owner may be substituted for a business credit report.

2 REQUIREMENTS

2.1 Contractor shall repair, refinish, replace, and install items to renovate the restroom as follows:

1. Participate in weekly meetings with the Contracting Officer's Representative (COR) and other team members, including a pre-construction meeting. Meetings will be held virtually or in person at the discretion of the COR.
2. Field measure scope area to confirm exact dimensions.
3. Follow all security entrance requirements listed below.
4. Maintain a safe working environment.
5. Provide all materials, tools, and labor needed to complete the job.
6. Always wear proper personal protective equipment (PPE).
7. Minimize noise, fumes, dust, and disruption.
8. Provide negative air fan/air scrubber during any construction activities that create smells or fumes.
9. Haul away from the building and discard all construction debris and trash.
10. Protect all surfaces along the pathway inside the building between the project area and the exterior single leaf metal access door and ramp. This includes putting up elevator wall protection provided by the building's operations and maintenance staff (there is not a freight elevator). Access to the working elevators must be shared and coordinated with other contractors and occupants in the building.
11. Items to be reused will be removed from the countertop and inside the cabinets by the occupants. Discard any remaining items and attachments.
12. Remove the existing laminate countertop, sink, backsplash, and cabinet.
13. Remove the existing linear fluorescent light and associated light niche.
 - a. Patch ceiling and walls.
14. Remove the existing toilet. Temporarily plug the drain to avoid migration of fumes into the space.
15. Remove the existing flooring and floor trim.
 - a. Due to the anticipated noise associated with this renovation, coordinate the proposed timing of work with the COR to minimize disruptions to the building occupants (after hours/weekend, which is outside the normal business hours of 8:30 AM CT to 5:00 PM CT, Monday through Friday).
 - b. Carefully remove and dispose of the existing flooring and floor trim. Protect adjacent finishes from damage.
 - c. Remove all residue, level, and prepare the floor as needed to receive the new flooring.
16. Remove the existing paper towel dispenser, soap dispenser, toilet paper dispenser, door stop wall protector, and mirror. Infill and patch all drywall walls in the room to provide a new level surface (minimum Level 3 drywall finish).
17. Install new flooring and threshold.
 - a. Level and prepare the subfloor to receive new floor tile. Existing subfloor is

- anticipated to be concrete.
- b. The new flooring shall extend under the new cabinet.
 - c. Provide a new black marble threshold at doorway into the room.
 - d. Provide consistent and equal joint spacing between the new floor tiles.
 - e. **Basis of design, tile:** *Dal-tile – Marble Attache, Nero mosaic (black with white veins), Linear Hexagon, MA83.*
 - f. **Basis of design, grout:** *Mapei, 5019 Pearl Gray.*
18. Install new floor trim.
- a. New trim tile shall match ceramic tile floor.
 - b. **Basis of Design:** *Dal-tile – Marble Attache, Nero, 3 x 24 Bullnose, shape number S43F9.*
19. Install two new wall sconces.
- a. Install power and wall boxes to accommodate the two new wall sconces. Equally space the sconces on the wall above sink as shown on the attached drawing. Wire sconces so that they operate with a switch that is separate from the exhaust fan.
 - b. Mount the sconces in the orientation shown on the attached drawings. (Sconces are mountable in different orientations.)
 - c. Provide four (4) light bulbs; E26 base, A19 shape, LED, 60-Watt maximum, soft white (2700K).
 - d. **Basis of Design:** Millennium Lighting 2801-BN Amberle 10" Tall Wall Sconce, finish: Brushed Nickel.
20. Install a new GFCI duplex power receptacle in the wall to the right of the sink in the location of the existing paper towel dispenser.
- a. Color of the receptacle and cover plate shall be black.
 - b. **Basis of Design:** Lutron CAR-15-GFST-BL 15A 125V Tamper Resistant Self-Testing GFCI Receptacle with matching cover plate.
21. Replace the existing light and fan switch and cover with new double switch in black. One switch shall control the wall sconces. The other switch shall control the exhaust fan.
- a. **Basis of Design:** Lutron Model MACL-L3S5-BL Maestro LED+ LED, Halogen, Incandescent Dimmer Light Switch with matching cover plate.
22. Install a new lower cabinet for the sink. New cabinet shall have a consistent grain pattern and finish color. The new cabinet shall be Architectural Woodwork Institute (AWI) custom grade, including dovetail joinery and soft close hinges and door slides. Shop drawings, including elevations, plans, and all dimensions, shall be provided to the COR for approval prior to ordering and installation of new cabinetry. Contractor shall revise shop drawings to accommodate changes provided by the COR. The cabinets shall be fabricated and finished off-site.
- a. **Wood type:** Wood shall be maple or equal as approved by the COR.
 - b. **Finish:** Semi-gloss black paint or equal as approved by the COR. At the COR's discretion, the COR may approve a standard color in the manufacturer's cabinet line if it closely matches Sherwin-Williams SW 7069 Iron Ore paint color.
 - c. **Cabinet style:** frameless, with flat panel/slab doors with 90-degree edges and corners.
 - d. Cabinet shall contain at least one upper drawer and two lower doors.
 - e. Contractor shall provide new door and drawer hardware as follows:
 - i. **Drawers:** *Top Knobs, Reeded 1-1/4 Inch Mushroom Cabinet Knob from the Chateau Collection, finish: polished nickel.*

- ii. **Doors:** *Top Knobs*, Reeded 5 Inch Center to Center Handle Cabinet Pull from the Chateau Collection, finish: polished nickel.
 - iii. Install filler pieces that match cabinet doors as needed on each side of the cabinet to ensure drawers do not scrape adjacent walls.
 - iv. **Basis of design:** *KITH, Metro Maple in Ebony finish* or equal approved by COR.
23. Install a new solid surface countertop that is a solid, non-porous, homogenous surfacing material composed of natural minerals and resins.
- a. Provide an opening in the countertop for the new sink specified in Item 24 below.
 - b. Provide a matching backsplash in the same material as the new countertop on the back and sides of the countertop, 4" high on sides with design as shown on drawings for the wall underneath the mirror; ogee edge detail.
 - c. **Basis of design:** *Silestone, Et marquina, Eternal – (black with white veins) in Suede n-boost 3 cm, with ogee edge detail* or equal as approved by the COR.
24. Install a new undermount vitreous china sink centered in the countertop.
- a. Rectangular basin with center drain and front overflow drain.
 - b. Undercounter mount with required brackets. Install a straight line of silicone sealant per manufacturer's recommendations.
 - c. Complete the drain installation and confirm that there are no leaks.
 - d. **Basis of design:** *Kohler K-20000-7 Caxton Rectangle 20-1/4" Undermount, finish Black Black*, or equal as approved by COR.
25. Install a new 8" widespread bathroom faucet with drain assembly.
- a. Three-hole faucet with dual level handles and deck mounted.
 - b. Apply silicone sealant and install per manufacturer's recommendations, confirming that there are no leaks.
 - c. **Basis of design:** *Signature Hardware, Model 357325 Enid 1.2 GPM Widespread Bathroom Faucet with Drain Assembly, finish: Brushed Nickel* or equal as approved by COR. If equal is approved by the COR, faucet color shall match new cabinet hardware.
26. Install new wallpaper.
- a. Repair and prime drywall to provide a smooth surface for new wallcovering.
 - b. Install new wallcovering per manufacturer's recommendations and ensure that pattern matches on all walls at seams and corners. The wallpaper shall run continuous around the protruding corner.
 - c. **Basis of design:** *Bellacor Candice Olson Modern Nature 2nd Edition Black Moonlight Pearls, BC#2366321, 27.25-inch pattern repeat (straight)*.
27. Install new toilet and toilet seat.
- a. Install new round toilet per manufacturer's instructions, including silicone sealant at the base. Confirm that there are no leaks at any of the water and drain connections. Toilet to be universal/ADA height, rimless design, 360 swirl flush with a left-hand lever.
 - b. Install new soft close round closed-front toilet seat with lid.
 - c. **Basis of Design, toilet:** *Toto Drake Round Toilet, model CST775CSF#51 with matching Tank in Black* or equal as approved by COR.
 - d. **Basis of Design, seat:** *Toto Soft Close Round Closed-Front Toilet Seat and Lid in Black* or equal as approved by COR.
28. Replace the ceiling.
- a. Remove the existing ceiling tiles, grid, and light cove.

- b. Install new support system and gypsum board ceiling. Tape and install drywall joint compound on all seams and screw attachments to provide a smooth surface ready for paint.
 - c. Paint the entire ceiling; color to match Sherwin-Williams SW 7014 Eider White in Flat/Matte finish.
29. Replace the existing exhaust vent.
- a. Provide hanging support as needed for the new exhaust vent with light. Connect to the existing venting system.
 - b. **Basis of Design:** *Aero Pure AP 100H-RVL-WHITE 100 CFM 1.6 Sone Quiet Ceiling.*
30. Provide and install all accessories.
- a. **Mirror:** Frameless, shaped beveled mirror accented by decorative corner elements finished in heavily burnished antiqued silver; Andretta by Grace Feyock, 19” wide x 29” high (specialty item).
 - b. **Toilet tank lever:** Signature Hardware Provincetown, Model 446677 Toilet Tank Lever in Brushed Nickel finish.
 - c. **Toilet paper holder:** Signature Hardware Provincetown, Model 446855 Wall Mounted Pivoting Toilet Paper Holder in Brushed Nickel finish.
 - d. **Towel bar:** Signature Hardware Provincetown, Model 446850 24” Towel Bar in Brushed Nickel finish.
 - e. **Paper Towel holder:** Everly Quinn Metal Freestanding Paper Towel Holder in Silver finish.
 - f. **Door hinge pin door stop:** Miseno MDS01SBMB Adjustable Solid Brass Hinge Pin Door stop in Black finish.
31. All materials shall have a lead time of six (6) weeks or less.
32. Perform a final cleaning of the space and return all displaced items.

2.2 Samples

The finishes listed as basis of design have been coordinated with each other and previously approved. Samples of all finishes shall be presented to a designated on-site reviewer and then sent to the COR via overnight delivery for confirmation and approval. **Any proposed “or equal” substitutions shall be clearly noted on the quote sheet along with an explanation for the substitution.** These include:

1. Solid surface countertop
2. Tile flooring and grout
3. New cabinet (shop drawings and physical sample of finish)
4. New wallcovering
5. Ceiling paint color
6. New toilet and toilet seat (cut sheets)
7. New mirror (cut sheet)
8. Sink and faucet (cut sheets)
9. New light switch (cut sheet)
10. New light sconces (cut sheet)
11. New exhaust fan with light (cut sheet)
12. New accessories (cut sheets)

2.3 Drawings

Refer to the attached drawings for additional notes detailing the scope requirements.

3 DELIVERABLES AND ACCEPTANCE CRITERIA

Contractor shall provide the following deliverables to ensure a successful project with minimal disruption to the building occupants.

The COR will review all deliverables for accuracy, quality, and completeness and will provide final acceptance of the work performed. The work shall meet the requirements listed herein and the requirements described in the attached drawings and shall be complete for the work to be occupied or utilized for its intended purpose.

Deliverable:	Acceptance Criteria:
Proposed work schedule	Within two (2) weeks of award, provide the COR with a proposed work schedule, including sample collection and review, material lead-times, on-site construction activities, and any needed coordination items with building maintenance. After review by the COR, revise the work schedule to work around court events if necessary.
On-site work	On-site work completed in two (2) weeks or less after all materials are in hand.
Product Data (samples and cutsheets), shop drawings	Submitted before materials are ordered and meets Section 2 requirements.
List of personnel on-site	Completed security forms submitted per the requirements in Section 5.
Worker escorting plan	Complies with the security requirements in Section 5.
Material removal and delivery plan	Complies with the security requirements in Section 5.
Indoor air quality strategy	Addresses any potential odors, fumes, dust, etc.
Daily reports during on-site work	Provide a brief daily email update with photos to the COR.
All labor and material to complete work	Meets Section 2 requirements, manufacturer, and industry standards for material and installation.
New cabinetry	New cabinetry shall be straight and aligned with adjacent surface without gaps and with consistent grain and stain color finish.
New cabinet doors and hardware	New cabinet doors shall be straight and aligned with adjacent surface without gaps and with consistent grain and stain color finish. Hardware shall be secured to cabinet doors and drawers to accommodate pull force needed to open the doors and drawers.
New electrical outlet and switches.	New electrical outlet shall function per GFCI code requirements. Electrical outlet and switch covers shall be level, flush with the wall, and without gaps or protruding screws.

New wall sconces	New wall sconces shall be evenly placed on wall per drawings, be level, and function on/off via the wall switch.
New countertop	New countertop shall be consistent in color and finish without scratches or dents. Cut edges shall be smooth and parallel to wall with minimal gaps. Exposed edge shall overhang lower cabinet doors and drawers. Countertop shall not contain any seams.
New backsplash	New backsplash shall be level and equally placed with smooth, consistent grout lines.
New sink and faucet	New sink shall be undermounted without gaps; sealant shall be smooth at the transition between sink and countertop. New faucet shall deliver both hot and cold water. Hot setting shall deliver hot water and cold setting shall deliver cold water. All connections shall be tight without leaks.
New toilet and toilet seat	New toilet shall be stable and flush on new floor tile with proper sealant and shall operate per industry standards. Toilet seat in matching color shall be properly secured and close softly.
New flooring	New flooring and floor trim shall be level, continuous, and uniform in color and texture, without gaps or scratches. The new transition at the door shall match the new flooring and be level with the new flooring and existing carpet.
New wallpaper	New wallpaper shall be flat without bubbles, tears, gaps, or visible seams. Edges shall be cut straight against adjacent surfaces.
New exhaust fan	New exhaust fan shall operate via the separate wall switch without uneven sound or squealing noises.
Final clean and placement of displaced items.	All surfaces in the restroom shall be free of temporary protection, dust, and dirt. Displaced items shall be returned to the original locations.
Punchlist walk-through and completion of issues identified during the review.	After substantial completion of work, coordinate with the COR on a time to conduct a walk-through with the COR to review the work and note any items that need to be corrected. Complete all punch list items within three (3) business days of walk-through with COR. Provide written documentation with photos of completed items. The COR will provide acceptance in coordination with Clause 2-20C, Warranty of Services.
Maintenance instructions and warranties	Provide manufacturer maintenance instructions and warranty information to the COR.

4 ENVIRONMENT:

LOCATION(S) FOR PERFORMANCE:

1. The scope area is in the Hugo L. Black United States Courthouse located at 1729 Fifth Avenue North, Birmingham, Alabama 35203 in an occupied office suite.
2. Refer to the attached drawings for the approximate dimensions and boundaries.

4.2 GOVERNMENT FURNISHED PROPERTY

1. The judiciary will provide access to the work areas requiring service.
2. Contractor shall coordinate on-site work with the COR to maintain access to and from adjacent spaces.
3. Locations near the work areas may have limited access at times but will not be blocked completely. Contractor shall protect all non-affected areas and always keep work area clean and neat. Contractor shall repair any damage done by contractor personnel to existing facilities, furnishings, and finishes at no cost to the judiciary. Contractor shall notify the COR of the discovery of any prior damage to the property before beginning work.
4. Contractor shall follow directions of building management regarding vehicle parking, storage of materials and equipment, and disposal of trash and construction waste. Contractor shall move materials into and out of the building through a single leaf metal side door.

4.3 CONTRACTOR FURNISHED MATERIAL

Contractor shall provide all labor and material for this project.

4.4 INDOOR AIR QUALITY

If any part of the work generates odors, fumes, or other airborne contaminants, contractor shall develop an indoor air quality mitigation strategy for review and approval by the COR before starting any work.

4.5 SITE VISIT

A site visit will be held on **Wednesday, 8 May 2024 at 11:00 AM CT** in the Hugo L. Black United States Courthouse located at **1729 Fifth Avenue North, Birmingham, Alabama 35203**. Additional site visits will not be held.

Please contact **Christina Roberts, Contracting Officer's Representative**, at christina_roberts@ca11.uscourts.gov or 404-335-6574 by **10:00 AM CT on Monday, 6 May 2024** if you plan to attend the site visit.

Contractors will be given an opportunity to conduct field measurements of the subject area prior to submitting a quote.

5 SECURITY REQUIREMENTS

Judiciary contract clauses that pertain to Security are listed in Clause 7-20, Security Requirements (APR 2013). *(See Provision B-1 below for link to full text of solicitation provisions and clauses.)*

1. Contractor shall complete and return the paperwork provided by the COR for all employees and subcontractors working onsite at least two (2) weeks before the start of work. The required information shall include (1) full name, (2) date of birth, and (3) Social Security number.
2. The contractor shall comply with all escorting requirements during on-site construction

activities. All workers shall be accompanied inside the building by an approved escort, which is a Court Security Officer (CSO) hired by the contractor specifically for the project. One CSO may escort a maximum of five (5) workers if escort always maintains visual oversight. A worker does not count towards the maximum if the worker has a General Services Administration (GSA) issued contractor badge. If there are more than 5 unbadged workers, then the services of an additional CSO are required.

3. The contractor shall procure and coordinate the services of a CSO to provide escorting services within the office suite and throughout the building during all on-site construction activities. The contractor shall procure and coordinate the services of a CSO through the U.S. Marshals Service (USMS) and the onsite security supervisor. The cost for one CSO is currently \$82.30 per hour (business hours and overtime hours) with a 4-hour minimum time block. The COR will provide names and contact information for the USMS and the onsite security supervisor after award.

4. If after hours work is approved by the COR, the services of two (2) Court Security Officers (CSOs) shall be required at a minimum.

5. The contractor shall comply with all screening requirements for entry into the building, which includes screening of all personnel, bags, tools, and materials.

6. Material movement into or out of the building shall be coordinated with the COR, on-site personnel designed by the COR, the escorting CSO, and any additional contractors working in the building.

(End of Statement of Work)

Using the quote sheet provided herein, email your quote no later than the date and time specified above. Late quotes will not be considered unless the judiciary determines, at its own discretion, that considering the late quote is in the judiciary's best interest and will not unduly delay the procurement.

The judiciary intends to make an award based on the **lowest priced, technically acceptable** quote. All items should be quoted as a **fixed price**. Payment terms will be considered **Net 30** unless more favorable terms are offered.

The period of performance is as indicated below:

The period of performance shall start on the date of award and end within twelve (12) weeks of the date of the award.

The COR will coordinate all work with the contractor. The contractor shall conduct all work between the hours of 8:30 AM and 4:30 PM CDT unless otherwise specified and approved by the COR. The contractor shall work around the schedule of Judiciary staff affected by the on-site construction work. Contractor shall coordinate with the COR in advance to limit loud activities to early morning or late afternoon.

The COR, at its sole discretion, may modify the schedule of work and the end of the period of performance. Changes to the schedule and the end date of the period of performance are not considered modifications of the contract.

The place of performance will be the Hugo L. Black United States Courthouse located at 1729 Fifth Avenue North, Birmingham, Alabama 35203.

Sincerely,

Stan Peters
Contracting Officer

Attachments: Quote Sheet
Terms and Conditions
Drawings
Wage Determination
Wage Rate Requirements (Davis-Bacon Act) Poster (WH-1321)

Quote Sheet for RFQ #20240401

Instructions for Quoter:

Provide the information requested here and below at Provision 3-5, Provision 3-20, and Clause 7-10:

Company name:	
DUNS number or UEI:	
Discount terms, if other than Net 30:	

Instructions for Quoter:

Fill in the unit price and extended price for each item of your quote and fill in the grand total amount or **submit a quote containing all the information requested below on your standard quotation form.**

Item	Description	Qty	Unit of Issue	Unit Price (\$)	Extended Price (\$)
1.	Renovation of restroom as described in Request for Quotation #20240401	1	Job		
2.					
3.					
4.					
5.					

Insert below the brand name and model number for any items you propose to furnish as an equal product:

GRAND TOTAL:	\$
---------------------	----

TERMS AND CONDITIONS

The following judiciary terms and conditions are incorporated into this request and will be included in the resulting order.

SOLICITATION PROVISIONS

Provision 3-5, Taxpayer Identification and Other Offeror Information (APR 2011)

(a) Definitions. "Taxpayer Identification (TIN)," as used in this provision, means the number required by the Internal Revenue Service (IRS) to be used by the offeror in reporting income tax and other returns. The TIN may be either a social security number or an employer identification number.

(b) All offerors shall submit the information required in paragraphs (d) and (e) of this provision to comply with debt collection requirements of 31 U.S.C. §§ 7701(c) and 3325(d), reporting requirements of 26 U.S.C. §§ 6041, 6041A, and implementing regulations issued by the IRS. If the resulting contract is subject to the payment reporting requirements, the failure or refusal by the offeror to furnish the information may result in a 31 percent reduction of payments otherwise due under the contract.

(c) The TIN may be used by the government to collect and report on any delinquent amounts arising out of the offeror's relationship with the government (31 U.S.C. § 7701(c)(3)). If the resulting contract is subject to payment recording requirements, the TIN provided hereunder may be matched with IRS records to verify the accuracy of the offeror's TIN.

(d) Taxpayer Identification Number (TIN): _____

- TIN has been applied for.
- TIN is not required, because:

Offeror is a nonresident alien, foreign corporation or foreign partnership that does not have income effectively connected with the conduct of a trade or business in the United States and does not have an office or place of business or a fiscal paying agent in the United States;

- Offeror is an agency or instrumentality of a foreign government;
- Offeror is an agency or instrumentality of the federal government.

(e) Type of Organization:

- sole proprietorship;
- partnership;
- corporate entity (not tax-exempt);
- corporate entity (tax-exempt);
- government entity (federal, state, or local);
- foreign government;
- international organization per 26 CFR 1.6049-4;
- other

(f) Contractor representations. The offeror represents as part of its offer that it is [____], is

not 51% owned and the management and daily operations are controlled by one or more members of the selected socio-economic group(s) below:

- Women Owned Business
- Minority Owned Business (if selected then one sub-type is required)
- Black American Owned
- Hispanic American Owned
- Native American Owned (American Indians, Eskimos, Aleuts, or Native Hawaiians)
- Asian-Pacific American Owned (persons with origins from Burma, Thailand, Malaysia, Indonesia, Singapore, Brunei, Japan, China, Taiwan, Laos, Cambodia (Kampuchea), Vietnam, Korea, The Philippines, U.S. Trust Territory of the Pacific Islands (Republic of Palau), Republic of the Marshall Islands, Federated States of Micronesia, the Commonwealth of the Northern Mariana Islands, Guam, Samoa, Macao, Hong Kong, Fiji, Tonga, Kiribati, Tuvalu, or Nauru)
- Subcontinent Asian (Asian-Indian) American Owned (persons with origins from India, Pakistan, Bangladesh, Sri Lanka, Bhutan, the Maldives Islands, or Nepal)
- Individual/concern, other than one of the preceding.

(end)

Provision 3-20, Certification Regarding Debarment, Suspension, Proposed Debarment, and Other Responsibility Matters (MAR 2019)

- (a) (1) The offeror certifies, to the best of its knowledge and belief, that:
 - (i) the offeror and/or any of its principals:
 - (A) are ___ are not ___ presently debarred, suspended, proposed for debarment, or declared ineligible for the award of contracts by any federal agency;
 - (B) have ___ have not ___, within the three-year period preceding this offer, been convicted of or had a civil judgment rendered against them for: commission of fraud or a criminal offense in connection with obtaining, attempting to obtain, or performing a public (federal, state, or local) contract or subcontract; violation of federal or state antitrust statutes relating to the submission of offers; or commission of embezzlement, theft, forgery, bribery, falsification or destruction of records, making false statements, tax evasion, violating federal criminal tax laws, or receiving stolen property;
 - (C) are ___ are not ___ presently indicted for, or otherwise criminally or civilly charged by a governmental entity with, commission of any of the offenses enumerated in paragraph (a)(1)(i)(B) of this provision;

(D) have ____, have not ____, within a three-year period preceding this offer, been notified of any delinquent federal taxes in an amount that exceeds \$3,500 for which the liability remains unsatisfied.

(1) Federal taxes are considered delinquent if both of the following criteria apply:

(i) The tax liability is finally determined. The liability is finally determined if it has been assessed. A liability is not finally determined if there is a pending administrative or judicial challenge. In the case of a judicial challenge to the liability, the liability is not finally determined until all judicial appeal rights have been exhausted.

(ii) The taxpayer is delinquent in making payment. A taxpayer is delinquent if the taxpayer has failed to pay the tax liability when full payment was due and required. A taxpayer is not delinquent in cases where enforced collection action is precluded.

(2) Examples.

(i) The taxpayer has received a statutory notice of deficiency, under I.R.C. § 6212, which entitles the taxpayer to seek Tax Court review of a proposed tax deficiency. This is not a delinquent tax because it is not a final tax liability. Should the taxpayer seek Tax Court review, this will not be a final tax liability until the taxpayer has exercised all judicial appeal rights.

(ii) The IRS has filed a notice of federal tax lien with respect to an assessed tax liability, and the taxpayer has been issued a notice under I.R.C. § 6320 entitling the taxpayer to request a hearing with the IRS Office of Appeals contesting the lien filing, and to further appeal to the Tax Court if the IRS determines to sustain the lien filing. In the course of the hearing, the taxpayer is entitled to contest the underlying tax liability because the taxpayer has had no prior opportunity to contest the liability. This is not a delinquent tax because it is not a final tax liability. Should the taxpayer seek Tax Court review, this will not be a final tax liability until the taxpayer has exercised all judicial appeal rights.

(iii) The taxpayer has entered into an installment agreement pursuant to I.R.C. § 6159. The taxpayer is making timely payments and is in full compliance with the agreement terms. The taxpayer is not delinquent because the taxpayer is not currently required to make full payment.

(iv) The taxpayer has filed for bankruptcy protection. The taxpayer is not delinquent because enforced collection action is stayed under [11 U.S.C. § 362](#) (the Bankruptcy Code).

(ii) The offeror ___ has ___ has not, within a three-year period preceding this offer, had one or more contracts terminated for default by any federal agency.

(2) "Principal," for the purposes of this certification, means an officer; director; owner; partner or a person having primary management or supervisory responsibilities within a business entity (e.g., general manager; plant manager; head of a division, or business segment, and similar positions).

This certification concerns a matter within the jurisdiction of an agency of the United States and the making of a false, fictitious, or fraudulent certification may render the maker subject to prosecution under [18 U.S.C. § 1001](#).

(b) The offeror shall provide immediate written notice to the contracting officer if, at any time prior to contract award, the offeror learns that its certification was erroneous when submitted or has become erroneous by reason of changed circumstances.

(c) A certification that any of the items in paragraph (a) of this provision exists will not necessarily result in withholding of an award under this solicitation. However, the certification will be considered in connection with a determination of the offeror's responsibility. Failure of the offeror to furnish a certification or provide such additional information as requested by the contracting officer may render the offeror nonresponsible.

(d) Nothing contained in the foregoing will be construed to require establishment of a system of records in order to render, in good faith, the certification required by paragraph (a) of this provision. The knowledge and information of an offeror is not required to exceed that which is normally possessed by a prudent person in the ordinary course of business dealings.

(e) The certification in paragraph (a) of this provision is a material representation of fact upon which reliance was placed when making award. If it is later determined that the offeror knowingly rendered an erroneous certification, in addition to other remedies available to the judiciary, the contracting officer may terminate the contract resulting from this solicitation for default.

(end)

Provision B-1, Solicitation Provisions Incorporated by Reference (SEP 2010)

This solicitation incorporates one or more solicitation provisions by reference, with the same force and effect as if they were given in full text. Upon request, the contracting officer will make their full text available. The offeror is cautioned that the listed provisions may include blocks that must be completed by the offeror and submitted with its quotation or offer. In lieu of submitting the full text of those provisions, the offeror may identify the provision by paragraph identifier and provide the appropriate information with its quotation or offer. Also, the full text of a solicitation provision may be accessed electronically at this address:

<http://www.uscourts.gov/procurement.aspx>.

(end)

The following provisions marked with an ‘X’ are incorporated by reference:

	2-15	Warranty Information (JAN 2003)
X	2-70	Site Visit (JAN 2003)
	2-85A	Evaluation Inclusive of Options (JAN 2003)
	2-85B	Evaluation Exclusive of Options (JAN 2003)
	2-85C	Evaluation of Options Exercised at Time of Contract Award (JAN 2003)
X	2-100	Brand Name or Equal (APR 2013)
	3-185	Evaluation of Compensation for Professional Employees (JAN 2003)
	4-155	Alternate Awards (JUN 2014)
	4-165	Price Proposal Instruction – Multi-Year Contract (JUN 2014)

CONTRACT CLAUSES

Applicable to both the solicitation and contract

Clause 2-20C, Warranty of Services (JAN 2003)

- (a) Definition. "Acceptance," as used in this clause, means the act of an authorized representative of the judiciary by which the judiciary assumes for itself, or as an agent of another, approves specific services, as partial or complete performance of the contract.

- (b) Notwithstanding inspection and acceptance by the judiciary or any provision concerning the conclusiveness thereof, the contractor warrants that all services performed under this contract will, at the time of acceptance, be free from defects in workmanship and conform to the requirements of this contract. The contracting officer will give written notice of any defect or nonconformance to the contractor within three (3) business days from the date of acceptance by the judiciary. This notice will state either
 - (1) that the contractor shall correct or re-perform any defective or nonconforming services; or
 - (2) that the judiciary does not require correction or re-performance.

- (c) If the contractor is required to correct or re-perform, it shall be at no cost to the judiciary, and any services corrected or re-performed by the contractor shall be subject to this clause to the same extent as work initially performed. If the contractor fails or refuses to correct or re-perform, the contracting officer may, by contract or otherwise, correct or replace with similar services and charge to the contractor the cost occasioned to the judiciary thereby, or make an equitable adjustment in the contract price.
- (d) If the judiciary does not require correction or re-performance, the contracting officer will make an equitable adjustment in the contract price.

(end)

Clause 6-20, Insurance – Work On or Within a Judiciary Facility (APR 2011)

- (a) The contractor shall, at its own expense, provide and maintain during the entire performance of this contract, at least the following kinds and minimum amounts of insurance:

- (1) Workman's Compensation and Employee's Liability Insurance

- The contractor shall comply with applicable federal and state workers' compensation and occupational disease statutes. If occupational diseases are not compensable under those statutes, they shall be covered under the employer's liability section of the insurance policy. Employer's liability coverage of at least \$100,000 per incident is required.

- (2) Automobile Liability Insurance

- The contractor shall have coverage at a minimum of \$200,000 per person; \$500,000 per occurrence for bodily injury; and \$20,000 per occurrence for property damage.

- (3) General Liability Insurance

- The contractor shall have coverage at a minimum of \$200,000 per person and \$500,000 per occurrence for death or bodily injury and \$20,000 per occurrence for property damage.

- (4) Self-Insurance

- If the contractor has been approved to provide a qualified program of self-insurance, the contractor must submit any proposed changes to the program to the contracting officer for approval.

- (b) Prior to beginning performance under this contract, the contractor shall provide the insurance carrier certification of the above minimum amounts.
- (c) The maintenance of insurance coverage as required by this clause is a continuing obligation, and the lapse or termination of insurance coverage without replacement coverage being obtained will be grounds for termination for default.
- (d) The certification evidencing required insurance shall contain an endorsement to the effect that any cancellation or any material change adversely affecting the judiciary's interest shall not be effective:
 - (1) for such period as the laws of the state in which this contract is to be performed prescribe; or
 - (2) until 30 days after the insurer or the contractor gives written notice to the contracting officer, whichever period is longer.
- (e) The contractor shall insert the substance of this clause, including this paragraph (e), in subcontracts under this contract that require work in a judiciary facility and shall require subcontractors to provide and maintain the required insurance. The contractor shall maintain a copy of all subcontractors' proofs of required insurance and shall make copies available to the contracting officer upon request.

(end)

Clause 7-10, Contractor Representative (JAN 2003)

- (a) The contractor's representative to be contacted for all contract administration matters is as follows (contractor complete the information):

Name: _____

Address: _____

Telephone: _____

E-mail: _____

Fax: _____

- (b) The contractor's representative shall act as the central point of contact with the judiciary, shall be responsible for all contract administration issues relative to this contract, and shall have full authority to act for and legally bind the contractor on all such issues.

(end)

Clause B-5, Clauses Incorporated by Reference (SEP 2010)

This contract incorporates one or more clauses by reference, with the same force and effect as if they were given in full text. Upon request, the contracting officer will make their full text available. Also, the full text of a clause may be accessed electronically at this address:

<http://www.uscourts.gov/procurement.aspx>.

(end)

Construction Wage Rate Requirements (Aug 2018)

(a) *Definition.*—"Site of the work"—

(1) Means—

(i) *The primary site of the work.* The physical place or places where the construction called for in the contract will remain when work on it is completed; and

(ii) *The secondary site of the work, if any.* Any other site where a significant portion of the building or work is constructed, provided that such site is-

(A) Located in the United States; and

(B) Established specifically for the performance of the contract or project;

(2) Except as provided in paragraph (3) of this definition, includes any fabrication plants, mobile factories, batch plants, borrow pits, job headquarters, tool yards, etc., provided-

(i) They are dedicated exclusively, or nearly so, to performance of the contract or project; and

(ii) They are adjacent or virtually adjacent to the "primary site of the work" as defined in paragraph (a)(1)(i), or the "secondary site of the work" as defined in paragraph (a)(1)(ii) of this definition;

(3) Does not include permanent home offices, branch plant establishments, fabrication plants, or tool yards of a Contractor or subcontractor whose locations and continuance in operation are determined wholly without regard to a particular Federal contract or project. In addition, fabrication plants, batch plants, borrow pits, job headquarters, yards, etc., of a commercial or material supplier which are established by a supplier of materials for the project before opening of bids and not on the Project site, are not included in the "site of the work." Such permanent, previously established facilities are not a part of the "site of the work" even if the operations for a period of time may be dedicated exclusively or nearly so, to the performance of a contract.

(b)

(1) All laborers and mechanics employed or working upon the site of the work will be paid unconditionally and not less often than once a week, and without subsequent deduction or rebate on any account (except such payroll deductions as are permitted by regulations issued by the Secretary of Labor under the Copeland Act (29 CFR Part 3)), the full amount of wages and bona fide fringe benefits (or cash equivalents thereof) due at time of payment computed at rates not less than those contained in the wage determination of the Secretary of Labor which is

attached hereto and made a part hereof, or as may be incorporated for a secondary site of the work, regardless of any contractual relationship which may be alleged to exist between the Contractor and such laborers and mechanics. Any wage determination incorporated for a secondary site of the work shall be effective from the first day on which work under the contract was performed at that site and shall be incorporated without any adjustment in contract price or estimated cost. Laborers employed by the construction Contractor or construction subcontractor that are transporting portions of the building or work between the secondary site of the work and the primary site of the work shall be paid in accordance with the wage determination applicable to the primary site of the work.

(2) Contributions made or costs reasonably anticipated for bona fide fringe benefits under section 1(b)(2) of the Construction Wage Rate Requirements statute on behalf of laborers or mechanics are considered wages paid to such laborers or mechanics, subject to the provisions of paragraph (e) of this clause; also, regular contributions made or costs incurred for more than a weekly period (but not less often than quarterly) under plans, funds, or programs which cover the particular weekly period, are deemed to be constructively made or incurred during such period.

(3) Such laborers and mechanics shall be paid not less than the appropriate wage rate and fringe benefits in the wage determination for the classification of work actually performed, without regard to skill, except as provided in the clause entitled Apprentices and Trainees. Laborers or mechanics performing work in more than one classification may be compensated at the rate specified for each classification for the time actually worked therein; provided that the employer's payroll records accurately set forth the time spent in each classification in which work is performed.

(4) The wage determination (including any additional classifications and wage rates conformed under paragraph (c) of this clause) and the Construction Wage Rate Requirements (Davis-Bacon Act) poster (WH-1321) shall be posted at all times by the Contractor and its subcontractors at the primary site of the work and the secondary site of the work, if any, in a prominent and accessible place where it can be easily seen by the workers.

(c)

(1) The Contracting Officer shall require that any class of laborers or mechanics which is not listed in the wage determination, and which is to be employed under the contract shall be classified in conformance with the wage determination. The Contracting Officer shall approve an additional classification and wage rate and fringe benefits therefor only when all the following criteria have been met:

(i) The work to be performed by the classification requested is not performed by a classification in the wage determination.

(ii) The classification is utilized in the area by the construction industry.

(iii) The proposed wage rate, including any bona fide fringe benefits, bears a reasonable relationship to the wage rates contained in the wage determination.

(2) If the Contractor and the laborers and mechanics to be employed in the classification (if known), or their representatives, and the Contracting Officer agree on the classification and wage rate (including the amount designated for fringe benefits, where appropriate), a report of the action taken shall be sent by the Contracting Officer to the Administrator of the:

Wage and Hour Division
U.S. Department of Labor
Washington, DC 20210

The Administrator or an authorized representative will approve, modify, or disapprove every additional classification action within 30 days of receipt and so advise the Contracting Officer or will notify the Contracting Officer within the 30-day period that additional time is necessary.

(3) In the event the Contractor, the laborers or mechanics to be employed in the classification, or their representatives, and the Contracting Officer do not agree on the proposed classification and wage rate (including the amount designated for fringe benefits, where appropriate), the Contracting Officer shall refer the questions, including the views of all interested parties and the recommendation of the Contracting Officer, to the Administrator of the Wage and Hour Division for determination. The Administrator, or an authorized representative, will issue a determination within 30 days of receipt and so advise the Contracting Officer or will notify the Contracting Officer within the 30-day period that additional time is necessary.

(4) The wage rate (including fringe benefits, where appropriate) determined pursuant to paragraphs (c)(2) and (c)(3) of this clause shall be paid to all workers performing work in the classification under this contract from the first day on which work is performed in the classification.

(d) Whenever the minimum wage rate prescribed in the contract for a class of laborers or mechanics includes a fringe benefit which is not expressed as an hourly rate, the Contractor shall either pay the benefit as stated in the wage determination or shall pay another bona fide fringe benefit or an hourly cash equivalent thereof.

(e) If the Contractor does not make payments to a trustee or other third person, the Contractor may consider as part of the wages of any laborer or mechanic the amount of any costs reasonably anticipated in providing bona fide fringe benefits under a plan or program; provided, That the Secretary of Labor has found, upon the written request of the Contractor, that the applicable standards of the Construction Wage Rate Requirements statute have been met. The Secretary of Labor may require the Contractor to set aside, in a separate account, assets for the meeting of obligations under the plan or program.

(end)

The following clauses marked with an 'X' are incorporated by reference:

	2-5B	Inspection of Services (APR 2013)
--	------	-----------------------------------

	2-20A	Incorporation of Warranty (JAN 2003)
	2-40B	Delivery of Excess Quantities (JAN 2003)
	2-50	Continuity of Services (JAN 2003)
	2-55	Privacy or Security of Safeguards (JAN 2003)
	2-80	Judiciary Property (JAN 2003)
	2-90C	Option to Extend Services (APR 2013)
	2-90D	Option to Extend the Term of the Contract (APR 2013)
	2-110	Option to Purchase Equipment (JAN 2003)
	2-125	Security for Advance Payment (APR 2013)
	2-130	Energy Efficiency in Energy-Consuming Products (APR 2013)
	2-135	Acquisition of EPEAT®-Registered Personal Computer Products (MAR 2019)
	2-140	Judiciary IT Security Standards (APR 2013)
	3-1	Contractor Use of Mandatory Sources of Products or Services (JUN 2012)
X	3-3	Provisions, Clauses, Terms and Conditions - Small Purchases (JUN 2014)
X	3-300	Registration in the System for Award Management (SAM)
X	3-305	Payment by Electronic Funds Transfer – System for Award Management (SAM) Registration
	4-150	Cancellation Under Multi-Year Contracts (JUN 2014)
	5-1	Payments under Personal and Professional Services Contracts (APR 2013)
	5-30	Authorization and Consent (JAN 2003)
	5-30	Alternate I (JAN 2003)
	6-10	Deposit of Assets Requirements (APR 2013)
	6-15	Deposit of Assets Instead of Surety Bonds (JAN 2003)
	6-65	Rights in Data – Special Works (JAN 2010)
	6-75	Rights to Data in an Offer (APR 2013)
	6-80	Rights in Data – Existing Works (JAN 2010)
	6-90	Notice and Assistance Regarding Patent and Copyright Infringement (APR 2010)
	6-110	Deferred Ordering of Technical Data or Computer Software (JUN 2014)
X	7-1	Contract Administration (JAN 2003)
X	7-5	Contracting Officer's Representative (APR 2013)
X	7-15	Observance of Regulations/Standards of Conduct (JAN 2003)
X	7-25	Indemnification (AUG 2004)
	7-45	Travel (APR 2013)
	7-55	Contractor Use of Judiciary Networks (JUN 2014)
	7-70	Judiciary Property Furnished "As Is" (APR 2013)
	7-95	Contractor Inspection Requirements (JAN 2003)
	7-115	Availability of Funds (JAN 2003)
	7-160	Limitation on Withholding of Payments (APR 2013)
	7-170	Notice of Intent to Disallow Costs (JAN 2003)
	7-180	Prohibition of Assignment of Claims (JUN 2012)
X	7-215	Notification of Ownership Changes (JAN 2003)

Restroom Renovation Drawings
Ninth Floor
Hugo L. Black U.S. Courthouse

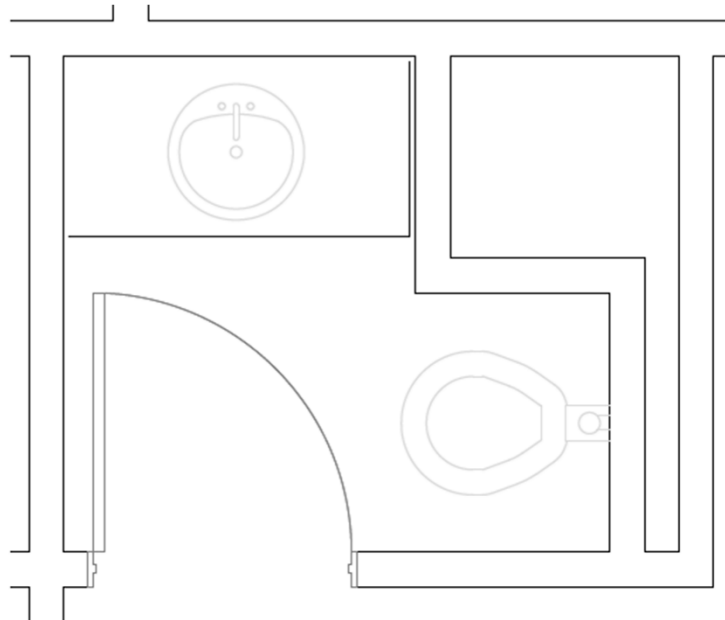

Existing Floor Plan

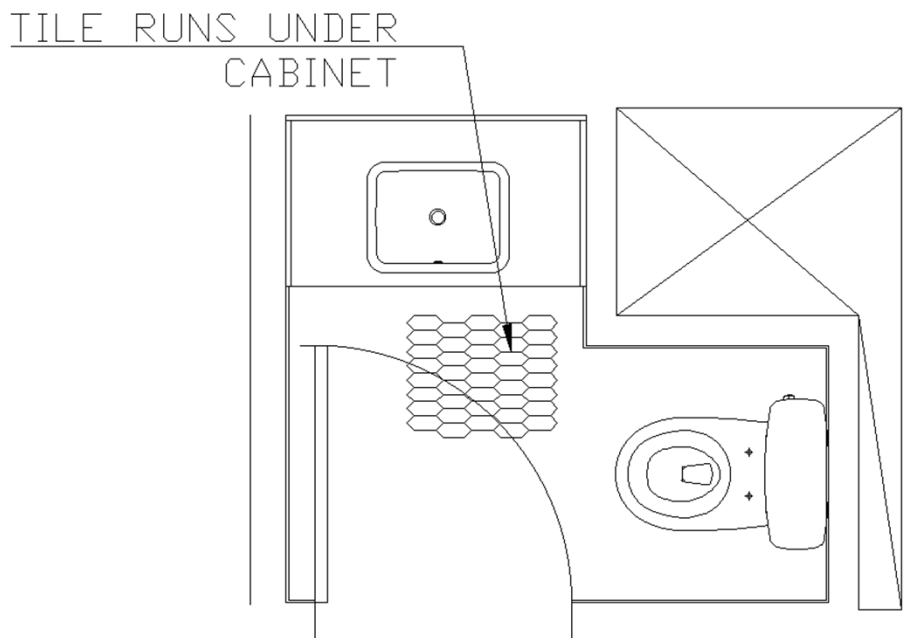

New Floor Plan

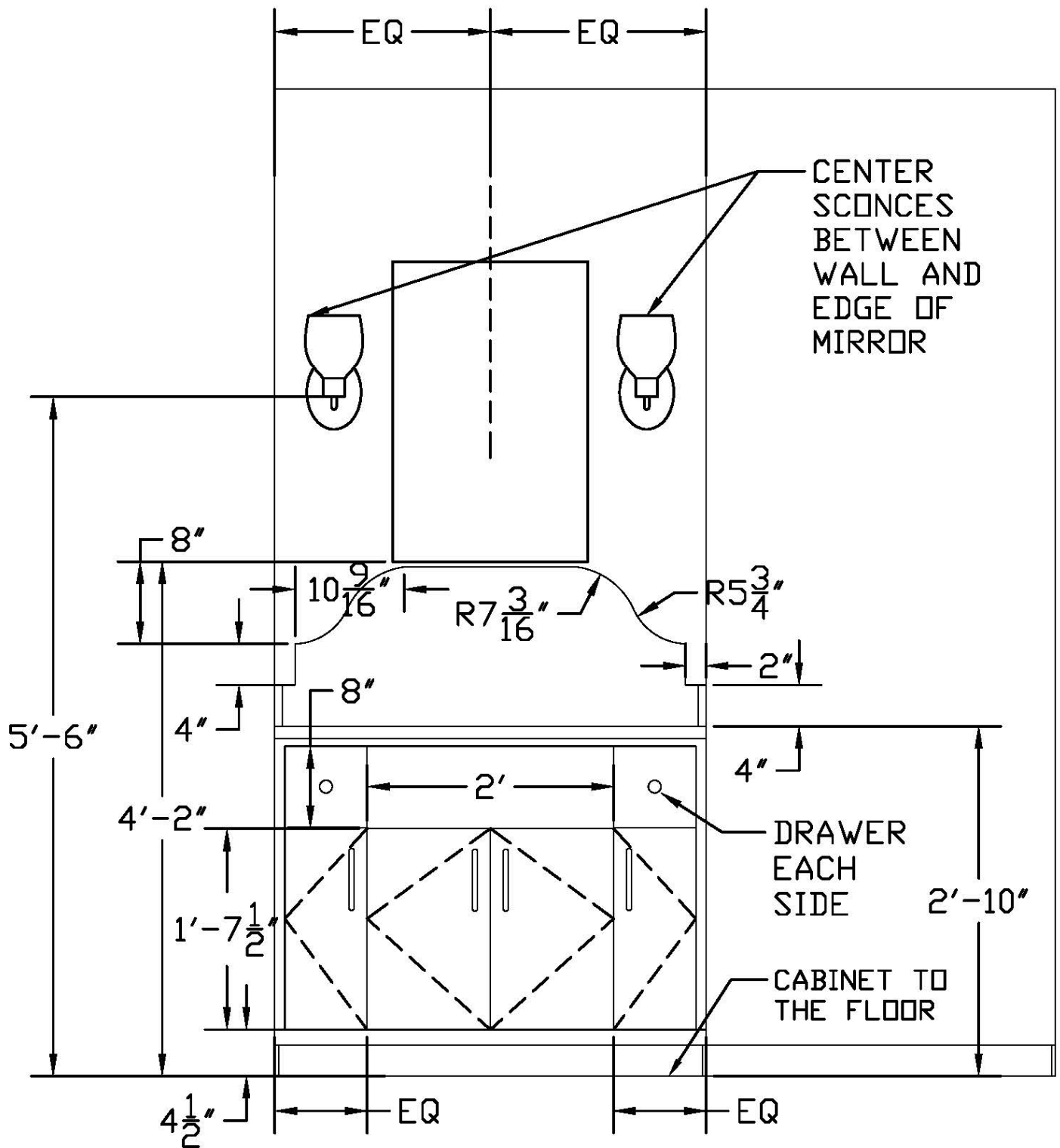

New Elevation

"General Decision Number: AL20240087 03/22/2024

Superseded General Decision Number: AL20230087

State: Alabama

Construction Type: Building
BUILDING CONSTRUCTION PROJECTS (does not include single family homes or apartments up to and including 4 stories)

County: Jefferson County in Alabama.

BUILDING CONSTRUCTION PROJECTS (does not include single family homes or apartments up to and including 4 stories).

Note: Contracts subject to the Davis-Bacon Act are generally required to pay at least the applicable minimum wage rate required under Executive Order 14026 or Executive Order 13658. Please note that these Executive Orders apply to covered contracts entered into by the federal government that are subject to the Davis-Bacon Act itself, but do not apply to contracts subject only to the Davis-Bacon Related Acts, including those set forth at 29 CFR 5.1(a)(1).

If the contract is entered into on or after January 30, 2022, or the contract is renewed or extended (e.g., an option is exercised) on or after January 30, 2022:	. Executive Order 14026 generally applies to the contract. . The contractor must pay all covered workers at least \$17.20 per hour (or the applicable wage rate listed on this wage determination, if it is higher) for all hours spent performing on the contract in 2024.
If the contract was awarded on or between January 1, 2015 and January 29, 2022, and the contract is not renewed or extended on or after January 30, 2022:	. Executive Order 13658 generally applies to the contract. . The contractor must pay all covered workers at least \$12.90 per hour (or the applicable wage rate listed on this wage determination, if it is higher) for all hours spent performing on that contract in 2024.

The applicable Executive Order minimum wage rate will be adjusted annually. If this contract is covered by one of the Executive Orders and a classification considered necessary for performance of work on the contract does not appear on this wage determination, the contractor must still submit a conformance request.

Additional information on contractor requirements and worker protections under the Executive Orders is available at <http://www.dol.gov/whd/govcontracts>.

Modification Number	Publication Date
0	01/05/2024
1	01/12/2024
2	03/22/2024

ASBE0078-001 10/01/2023

	Rates	Fringes
ASBESTOS WORKER/HEAT & FROST INSULATOR.....	\$ 30.50	16.10

BOIL0108-001 01/01/2021

	Rates	Fringes
BOILERMAKER.....	\$ 30.49	23.13

ENGI0312-001 10/01/2013

	Rates	Fringes
POWER EQUIPMENT OPERATOR		
Crane.....	\$ 27.05	11.38
Forklift.....	\$ 26.05	11.38

IRON0092-003 09/01/2023

	Rates	Fringes
IRONWORKER, STRUCTURAL.....	\$ 32.16	13.13

IRON0092-007 09/01/2023

Rates	Fringes
-------	---------

IRONWORKER, REINFORCING.....\$ 32.16 13.13

* PLUM0091-001 03/01/2024

	Rates	Fringes
PIPEFITTER (Includes HVAC Pipe Installation).....	\$ 33.00	15.01

* SUAL2015-015 08/02/2017

	Rates	Fringes
BRICKLAYER.....	\$ 22.00	0.00
CARPENTER, Includes Drywall Finishing/Taping, Drywall Hanging, Form Work, and Scaffold Builder.....	\$ 18.43	0.00
CEMENT MASON/CONCRETE FINISHER...	\$ 19.19	0.00
ELECTRICIAN.....	\$ 17.51	2.40
GLAZIER.....	\$ 23.00	5.64
LABORER: Common or General.....	\$ 14.63 **	3.88
LABORER: Mason Tender - Brick...	\$ 12.22 **	0.00
LABORER: Mason Tender - Cement/Concrete.....	\$ 14.23 **	0.00
LABORER: Pipelayer.....	\$ 15.59 **	0.00
OPERATOR: Backhoe/Excavator/Trackhoe.....	\$ 18.93	4.20
OPERATOR: Bulldozer.....	\$ 19.96	0.40
OPERATOR: Grader/Blade.....	\$ 17.52	0.89
OPERATOR: Loader.....	\$ 14.69 **	0.00
OPERATOR: Roller.....	\$ 14.00 **	1.78
PAINTER (Brush and Roller).....	\$ 15.31 **	1.41
PAINTER: Spray.....	\$ 14.31 **	0.00

PLUMBER, Excludes HVAC Pipe Installation.....	\$ 18.97	0.36
ROOFER.....	\$ 13.66 **	0.00
SHEET METAL WORKER, Includes HVAC Duct Installation.....	\$ 28.00	4.17
SPRINKLER FITTER (Fire Sprinklers).....	\$ 20.00	3.77
TILE SETTER.....	\$ 20.00	0.00
TRUCK DRIVER: Dump Truck.....	\$ 13.60 **	0.00

WELDERS - Receive rate prescribed for craft performing operation to which welding is incidental.

=====

** Workers in this classification may be entitled to a higher minimum wage under Executive Order 14026 (\$17.20) or 13658 (\$12.90). Please see the Note at the top of the wage determination for more information. Please also note that the minimum wage requirements of Executive Order 14026 are not currently being enforced as to any contract or subcontract to which the states of Texas, Louisiana, or Mississippi, including their agencies, are a party.

Note: Executive Order (EO) 13706, Establishing Paid Sick Leave for Federal Contractors applies to all contracts subject to the Davis-Bacon Act for which the contract is awarded (and any solicitation was issued) on or after January 1, 2017. If this contract is covered by the EO, the contractor must provide employees with 1 hour of paid sick leave for every 30 hours they work, up to 56 hours of paid sick leave each year. Employees must be permitted to use paid sick leave for their own illness, injury or other health-related needs, including preventive care; to assist a family member (or person who is like family to the employee) who is ill, injured, or has other health-related needs, including preventive care; or for reasons resulting from, or to assist a family member (or person who is like family to the employee) who is a victim of, domestic violence, sexual assault, or stalking. Additional information on contractor requirements and worker protections under the EO is available at <https://www.dol.gov/agencies/whd/government-contracts>.

Unlisted classifications needed for work not included within

the scope of the classifications listed may be added after award only as provided in the labor standards contract clauses (29CFR 5.5 (a) (1) (iii)).

The body of each wage determination lists the classification and wage rates that have been found to be prevailing for the cited type(s) of construction in the area covered by the wage determination. The classifications are listed in alphabetical order of ""identifiers"" that indicate whether the particular rate is a union rate (current union negotiated rate for local), a survey rate (weighted average rate) or a union average rate (weighted union average rate).

Union Rate Identifiers

A four letter classification abbreviation identifier enclosed in dotted lines beginning with characters other than ""SU"" or ""UAVG"" denotes that the union classification and rate were prevailing for that classification in the survey. Example: PLUM0198-005 07/01/2014. PLUM is an abbreviation identifier of the union which prevailed in the survey for this classification, which in this example would be Plumbers. 0198 indicates the local union number or district council number where applicable, i.e., Plumbers Local 0198. The next number, 005 in the example, is an internal number used in processing the wage determination. 07/01/2014 is the effective date of the most current negotiated rate, which in this example is July 1, 2014.

Union prevailing wage rates are updated to reflect all rate changes in the collective bargaining agreement (CBA) governing this classification and rate.

Survey Rate Identifiers

Classifications listed under the ""SU"" identifier indicate that no one rate prevailed for this classification in the survey and the published rate is derived by computing a weighted average rate based on all the rates reported in the survey for that classification. As this weighted average rate includes all rates reported in the survey, it may include both union and non-union rates. Example: SULA2012-007 5/13/2014. SU indicates the rates are survey rates based on a weighted average calculation of rates and are not majority rates. LA indicates the State of Louisiana. 2012 is the year of survey on which these classifications and rates are based. The next number, 007

in the example, is an internal number used in producing the wage determination. 5/13/2014 indicates the survey completion date for the classifications and rates under that identifier.

Survey wage rates are not updated and remain in effect until a new survey is conducted.

Union Average Rate Identifiers

Classification(s) listed under the UAVG identifier indicate that no single majority rate prevailed for those classifications; however, 100% of the data reported for the classifications was union data. EXAMPLE: UAVG-OH-0010 08/29/2014. UAVG indicates that the rate is a weighted union average rate. OH indicates the state. The next number, 0010 in the example, is an internal number used in producing the wage determination. 08/29/2014 indicates the survey completion date for the classifications and rates under that identifier.

A UAVG rate will be updated once a year, usually in January of each year, to reflect a weighted average of the current negotiated/CBA rate of the union locals from which the rate is based.

WAGE DETERMINATION APPEALS PROCESS

1.) Has there been an initial decision in the matter? This can be:

- * an existing published wage determination
- * a survey underlying a wage determination
- * a Wage and Hour Division letter setting forth a position on a wage determination matter
- * a conformance (additional classification and rate) ruling

On survey related matters, initial contact, including requests for summaries of surveys, should be with the Wage and Hour National Office because National Office has responsibility for the Davis-Bacon survey program. If the response from this initial contact is not satisfactory, then the process described in 2.) and 3.) should be followed.

With regard to any other matter not yet ripe for the formal process described here, initial contact should be with the Branch of Construction Wage Determinations. Write to:

Branch of Construction Wage Determinations
Wage and Hour Division
U.S. Department of Labor
200 Constitution Avenue, N.W.
Washington, DC 20210

2.) If the answer to the question in 1.) is yes, then an interested party (those affected by the action) can request review and reconsideration from the Wage and Hour Administrator (See 29 CFR Part 1.8 and 29 CFR Part 7). Write to:

Wage and Hour Administrator
U.S. Department of Labor
200 Constitution Avenue, N.W.
Washington, DC 20210

The request should be accompanied by a full statement of the interested party's position and by any information (wage payment data, project description, area practice material, etc.) that the requestor considers relevant to the issue.

3.) If the decision of the Administrator is not favorable, an interested party may appeal directly to the Administrative Review Board (formerly the Wage Appeals Board). Write to:

Administrative Review Board
U.S. Department of Labor
200 Constitution Avenue, N.W.
Washington, DC 20210

4.) All decisions by the Administrative Review Board are final.

=====

END OF GENERAL DECISION"

EMPLOYEE RIGHTS

UNDER THE DAVIS-BACON ACT

FOR LABORERS AND MECHANICS EMPLOYED ON FEDERAL OR FEDERALLY ASSISTED CONSTRUCTION PROJECTS

PREVAILING WAGES

You must be paid not less than the wage rate listed in the Davis-Bacon Wage Decision posted with this Notice for the work you perform.

OVERTIME

You must be paid not less than one and one-half times your basic rate of pay for all hours worked over 40 in a work week. There are few exceptions.

ENFORCEMENT

Contract payments can be withheld to ensure workers receive wages and overtime pay due, and liquidated damages may apply if overtime pay requirements are not met. Davis-Bacon contract clauses allow contract termination and debarment of contractors from future federal contracts for up to three years. A contractor who falsifies certified payroll records or induces wage kickbacks may be subject to civil or criminal prosecution, fines and/or imprisonment.

APPRENTICES

Apprentice rates apply only to apprentices properly registered under approved Federal or State apprenticeship programs.

PROPER PAY

If you do not receive proper pay, or require further information on the applicable wages, contact the Contracting Officer listed below:

Stan Peters, Contracting Officer
U.S. Court of Appeals for the Eleventh Circuit
56 Forsyth Street NW
Atlanta, Georgia 30303

or contact the U.S. Department of Labor's Wage and Hour Division.



WAGE AND HOUR DIVISION
UNITED STATES DEPARTMENT OF LABOR

1-866-487-9243
TTY: 1-877-889-5627
www.dol.gov/whd

